

Installation Sheet - OSID Smoke Detection System

This installation sheet provides information on how to install the OSID Smoke Detection System. Full product information can be found in the Product Guide (Document No. 15204).

OSID Alignment Tools for the Emitter and Imager are sold separately. They are required for all product installations. Please contact your local Xtralis supplier for ordering information.

OSID Installation Kit (OSID-INST)

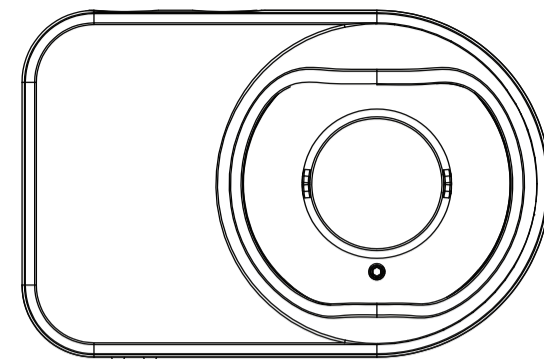

1 Determine the positions of the Imager and Emitter Components.

Make sure that the intended mounting locations meet the following criteria:

- Emitter spacing must comply with local codes and standards (B)
- Emitters must be located within the Field of View (FOV) of the Imager (A)
- Clear path between the Emitter and Imager
- Mounted well above the head-height of a person
- Avoid direct sunlight onto the units

When securing the detector to the mounting surface, mount the Imager first so that the approximate edges of its field of view can be determined. This will show the region in which the Emitter units can be located.

The Imager and Emitter/s should be placed within a distance H below the ceiling. This value will vary according to regional specifications, geometry, and specific requirements for the installation. The distance H for flat ceilings is shown in the following table.

Standard	Distance from Ceiling (H)
NFPA72	-
AS1670.1	25 to 600 mm (1 to 23.6 in.)
BS5839.1	25 to 600 mm (1 to 23.6 in.)
GB50166	300 to 1000 mm (11.8 to 39.4 in.)

Basic spacing requirements for "S" in diagram (B) are shown in the following table.

Standard	Maximum Spacing
NFPA72	18.3 m (60 ft)
AS1670.1	14 m (45.9 ft)
BS5839.1	15 m (49.2 ft)
GB50166	14 m (45.9 ft)

For full information on spacing requirements, please refer to your local codes and standards.

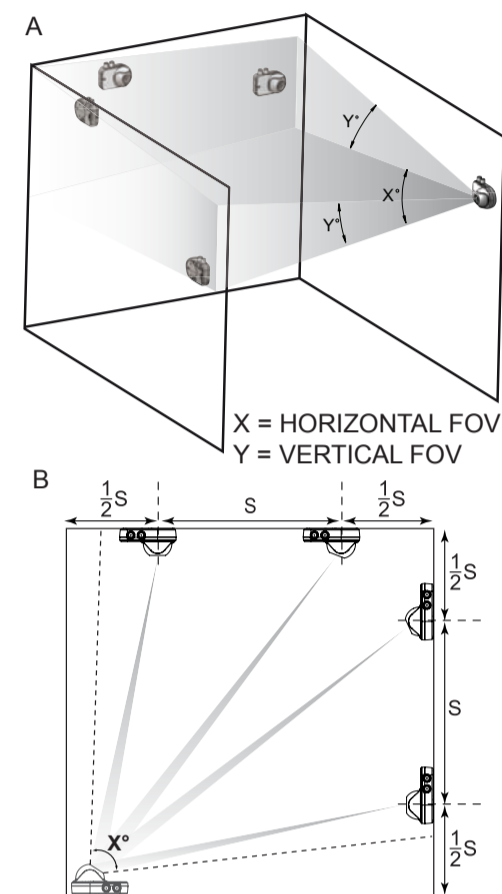

2 Detach Mounting Bracket and Front Cover.

- To Detach the unit from the Mounting Bracket (A), open the front cover and with a screwdriver push the lip backwards to then slide the unit up to detach from the Mounting Bracket
- To provide cable access to the Termination Card of the Imager or externally-powered Emitter, use a screw driver as shown in (B) to remove the Front Cover (C) from the main assembly. Remove the cut-outs from the back or top of the main assembly by using a sharp blade to cut around the circular discs.

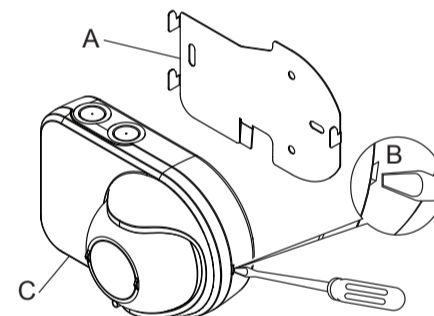

3 Mounting via Mounting Bracket (Option 1):

Please follow the instructions in this step if you have chosen to secure the detector component to the mounting surface using the supplied mounting bracket. If mounting directly to the mounting surface, please skip to Step 4.

- Using the screw holes of the bracket as a template, mark the installation point (A).
- Use the appropriate fasteners to fix the mounting brackets to the mounting surface. It is recommended that starwashers are used to prevent the brackets slipping.
- Attach the rear assembly of the component onto the mounting brackets (B)
- When mounting the Imager units onto the brackets, ensure that the ribbon cable at the back of the front ball does not get caught between the unit and the bracket, as movement of the front ball may pull the ribbon cable out of the connectors.

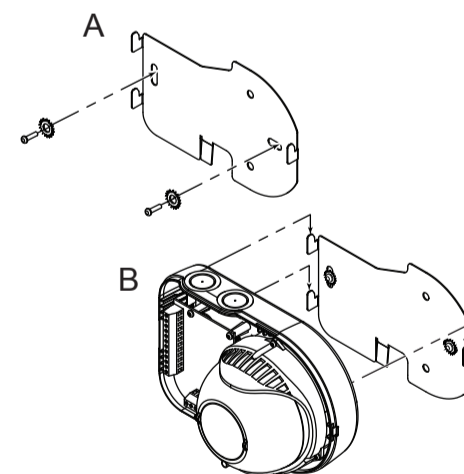

4 Mounting directly to the mounting surface (Option 2):

Follow this step if you have chosen to secure the detector component directly onto the mounting surface without using the supplied mounting bracket.

- Drill the mounting screw holes of the detector component (three places) (A).
- Using the drilled screw holes as a template, mark the installation point.
- Use appropriate fasteners to secure the detector component to the mounting surface.

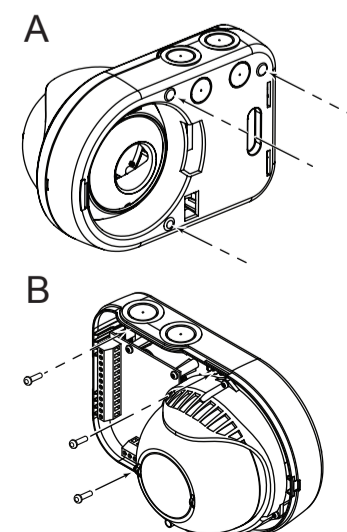

5 Configure System via the DIP Switches on the Termination Card of the Imager:

A. Fire Alarm Thresholds (Switch Pair A, Switch no. 1 & 2)	00	Not Configured (Trouble / Fault signaled)	C. Alarm Latching (Switch C, Switch no. 6)	0	Non-Latching
	10	Low (Highest Sensitivity)		1	Latching
	01	Medium (Medium Sensitivity)	D. Dust Rejection (Switch D, Switch no. 7)	0	Disabled
	11	High (Lowest Sensitivity)		1	Enabled (Increased tolerance to dust events resulting in fewer Faults signaled)
B. Number of Emitters (Switch Group B, Switch no. 3, 4 & 5)	000	Not Configured (Trouble / Fault signaled)	E. Enhanced Mode (Switch no. 9)	0	Disabled (EN54-12 Approved 6dB Alarm enabled) for UL 268 Approved units, set to 0
	100	1 Emitter present		1	Enabled (Not EN54-12 approved. Object intrusion producing 6dB attenuation gives a Fault instead of Alarm)
	010	2 Emitter present			
	110	3 Emitter present			
	001	4 Emitter present			
	101	5 Emitter present			
	011	6 Emitter present			
111	7 Emitter present	F. Not Used (Switch no. 8 & 10)	0	Unused DIP switches should be set to 0	

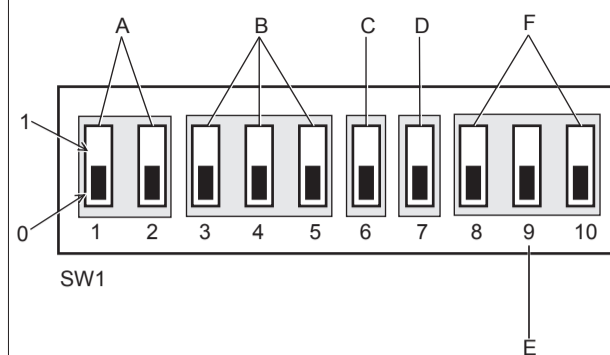

6 Wire the Termination Card on the Imager and Emitters:

Note: This step does not apply to battery-powered Emitters.

For Imagers:

1. Wire the initiating device circuit on the Imager Termination Card using the FIRE and FAULT relay terminals for a four-wire (A) device connection. For more detail, please refer to the Product Guide.
2. Wire external power to the unit via the POWER terminals.
3. Wire the Remote Indicator (B), heater power supply (C) and external RESET input (D) if required.
4. Re-attach the front cover of the Imager.

For externally-powered Emitters:

1. Connect power to the Emitter via the Vin and Vout terminals (E) on the Termination Card.
2. Re-attach the front cover of the Emitter.

Note: Analog Addressable Input Modules can also be used with the system. For further detail, please consult the Product Guide.

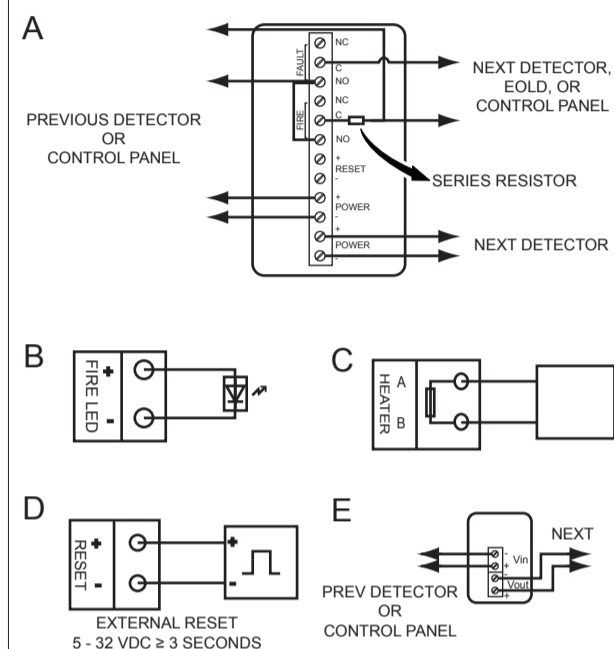

Manually adjust the Emitter/s and Imager until they are aligned:

Note: The OSID Laser Alignment Tool must be used to align the system.

7 Follow these steps to adjust the optical sphere (A) of the detector component to align the system:

1. Switch on and insert the OSID Alignment Tool in the alignment hole (B).
2. To align an Emitter, move the alignment tool until the laser beam points near the Imager and within the limits shown in Diagram C. Rotate the alignment tool 90° clockwise to lock the sphere into place and activate the Emitter. A STOP position will be felt when the sphere is locked.
3. To align the Imager, use the OSID Alignment Tool to position the Imager to point directly towards a single Emitter or in the gravitational centre of multiple Emitters. Rotate the alignment tool 90° clockwise to lock the sphere into place. A STOP position will be felt when the sphere is locked.
4. Make sure that the alignment of the Emitter or Imager is according to the specified limits after locking the sphere. Remove the laser tool.

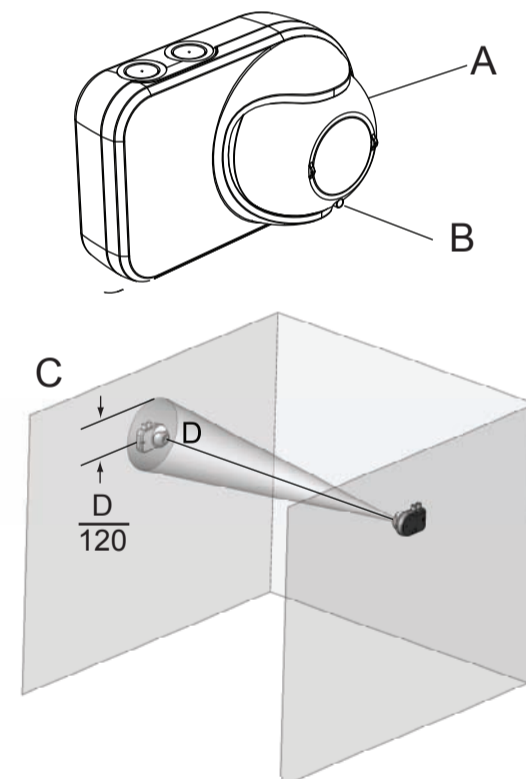

8 Initiate Training Mode:

Once mounted, final system alignment is achieved by initiating Training Mode:

1. Ensure that all the spheres of the Emitters/Imager are locked in place and externally-powered Emitters are powered.
2. Apply power to the Imager to initiate Training Mode.

After powering up the Imager, the Imager will search for Emitters in its field of view, and the Trouble LED will indicate that the detector is in Training Mode. Training Mode takes about 10 minutes to complete, after which the detector will start normal operation or report a Trouble Code. Refer to the OSID Product Guide (Document

